



Welcome to Newington Primary School

Primary One Information Booklet



Welcome to Newington Primary School

At Newington Primary School we aim to create a happy, relaxed atmosphere in which every child feels safe, secure and valued.

We believe that education is a partnership between school and home. We recognise and encourage the central role that you as a parent play in your child's development and welcome your support.

Every child in Scotland is entitled to experience a broad general education. At Newington Primary School we aim to provide a well-balanced curriculum which nurtures successful learners, confident individuals, effective contributors and responsible citizens. Remember your child is unique and their educational journey will differ from that of others. Please do not make comparisons, continue to praise and encourage them making their lifelong learning a positive experience.



Transition Process

We appreciate that the transition from Nursery to Primary 1 can be an anxious and confusing time for parents. At Newington Primary School we have worked hard to ensure that your child has a smooth, happy transition into Primary 1 and that they will thrive on the new experience.

We have already established a transition programme which involves Infant Staff working together to ensure a natural progression from Nursery to Primary 1.

Our transition programme involves:

- Regular meetings between Nursery and Infant Staff.
- Primary 1 teachers observe pupils within the Nursery environment.
- Nursery visits to Primary 1 classroom, infant playground, open area, pupil toilets and dining hall.
- Induction Day

This booklet was initially developed by a parent/staff working group. Hopefully it will provide some useful information and reassure those of you feel nervous about letting your child take those next steps in their education.



Key People for You to Recognise



Mr Torbett,
Headteacher



Mr Armstrong,
Depute Head



Mrs Ferguson,
Depute Head



Miss Hollis,
Primary 1A



Mrs Murray,
Primary P1B



Miss MacDonald,
Early Years
Assistant

Key People for You to Recognise



Mrs Glass,
Learning
Assistant



Mrs McKend,
Learning
Assistant



Mrs Patterson,
Secretary



Mrs Hind,
Secretary



Mr Kennedy,
Janitor



Mrs Davidson,
Playground
Supervisor

Do all the children start together on the first day?

The big change for everyone this year will see P1 pupils undertake full days from Tuesday 21st August, 2018, this has been set by the Education Committee. The children will go for lunch at 12 noon initially, until we get the lunch routines sorted, and dismissed from school at 3.05pm. The staff team will work with the pupils to make this new arrangement work, I'm sure.

What happens on the first day?

On the first day of school parents should bring their children to the Infant Playground. Parents are encouraged to bring their child into school, help them to hang up their coat and find their seat. Staff will check what your child is having for lunch and issue letters. You can then say your goodbyes. Any pictures taken are for your own domestic home use and shouldn't be posted on Social Media, no videos should be taken or posted - we don't have image consent for all pupils.



Where is the Infant Playground?

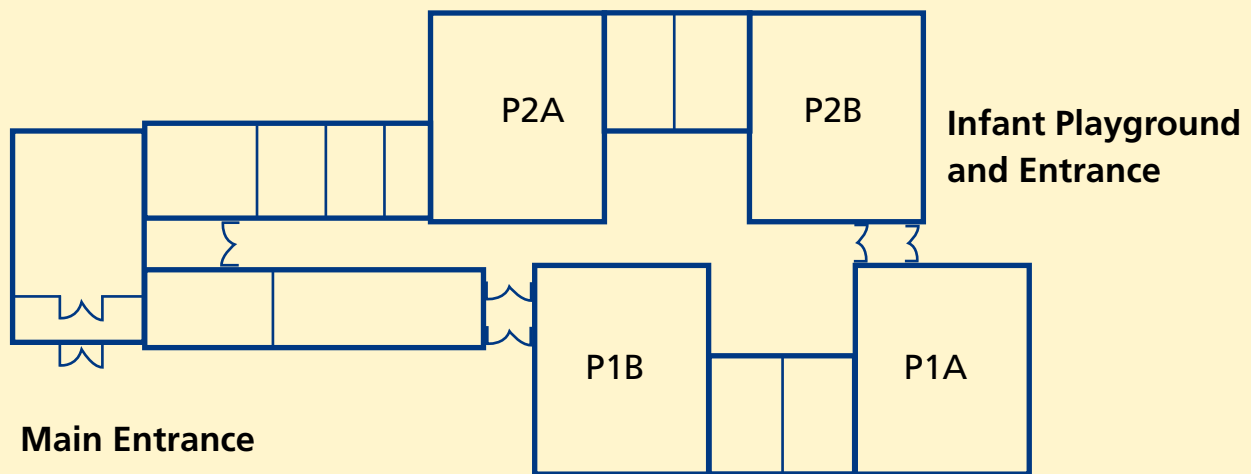

The Primary 1 Day

9am	Day begins
10.35-10.55am	Interval
12.30pm	Lunchtime
3.05pm	Home time



At the end of each day your child should be collected by an adult. It is very important to your child that they know who is collecting them and that they are on time. Please let us know if someone unfamiliar to staff is collecting your child or if you are running late.

Where possible make all arrangements in advance. The office can be overwhelmed by requests to pass on messages and information and it can be upsetting for the pupils too.

What does my child need to take to school?

- 🍏 Indoor Shoes – your child will need a pair of shoes which should be kept in school at all times. Preferably not black plimssoles. A spare pair of trainers (velcro fastening) are ideal as they will fully support your child's growing feet during P.E. lessons.
- 🍏 P.E. Kit – a t-shirt and pair of shorts should be kept in your child's school bag. It would be a good idea to put this into your child's bag on a Monday and leave there until Friday. Please note, football strips are not appropriate for school.
- 🍏 Snack – your child will be allowed to take a snack out at Interval. This snack may be a piece of fruit, a bag of crisps or a small **nut free** chocolate bar/biscuit. Please don't send three or four things – time is short and tummies are small. Snacks should be kept in school bags.
- 🍏 Water – we are a health promoting school and your child will be encouraged to drink water throughout the day. A sports bottle can be brought from home and refilled each day.
- 🍏 Milk Money – pupils have the opportunity to buy and drink milk in school. Milk money can only be paid on a Thursday morning for the following week (presently £1.05 per week). If your child does not want milk they can bring a drink of juice into school (no fizzy drinks please).
- 🍏 Change of Clothes – it is advisable to have a change of clothes in your child's school bag in case of a 'little accident'. Please ensure that **all** items of clothing have your child's name clearly written on them.

We will provide all resources needed for classroom activities. A pencil case is not required.

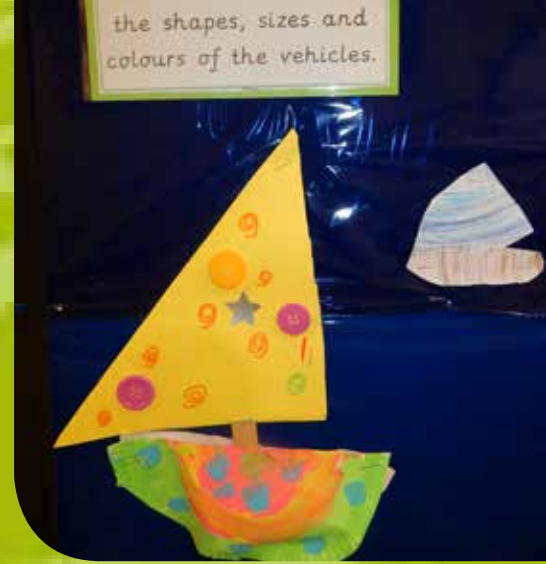

What can my child have for lunch?

Packed Lunch – Pupils will be encouraged to eat the contents of their packed lunch box. Please do not put in more food than your child would normally eat at home. A sandwich, drink, yogurt, biscuit and a piece of fruit will probably be enough. All lunch boxes should be clearly named.

School Meals – All Primary 1 children are entitled to free school meals. Children have the choice of a hot meal, baked potato or choice of sandwich bar.

Home Dinners – If your child is going home for lunch they can be collected at the office at 12.30pm and should be returned to the main office before 1.15pm when classes resume.



Do you have playground supervisors?

There will be a learning assistant in the playground from 8.45 am onwards.

At morning interval and lunch time Mrs Davidson and Primary 7 monitors supervise the children. They will ensure all children have someone to play with. If any children suffer a minor scrape or bump they are taken to Mrs Patterson and Mrs Hind who will administer first aid.

What if my child is ill?

If your child is too ill to attend school please **text** the 24hr Absence Line on: **07860 029432**.

Their class teacher will then be informed.

If a child becomes unwell at school we will contact a parent/guardian, if they are not available we will phone the nominated emergency contact. With this in mind please ensure that the school is kept informed about changes to phone numbers.

If your child has to take medication during school hours it should be brought to the office. You will then have to fill out a form consenting to its administration.

Head Lice – is an ongoing problem and can spread quickly in a school. Prevention is the best method for keeping it in check. It is advisable to check hair thoroughly once a week and after shampooing, use conditioner on your child's hair and then comb through with a head lice comb.





How will I know what goes on at school

Children who start school are notoriously silent about what they do all day. When asked they often say, 'Nothing' or 'I just played'. So how do you find out more?

There will be an Open Event early in the session. This is an opportunity to meet with Miss Hollis and Mrs Murray to find out about the curriculum e.g. Jolly Phonics.

There will be two parents' evenings during the session where you have an individual consultation with your child's teacher.

A report card will be issued in June 2019. These will provide information on your child's development and progression. If a duplicate copy is required please request this at the school office.

Letters home will be put into homework folder or school bags – please check these daily. Please help the school by sending back all returns.

We also use group texts regularly to give parents updates. Make sure we have an up to date number so you don't miss out on these.

What should I do if I have any concerns?

Within the Infant Department we employ an open door policy. This means that should you have any concerns regarding your child you can approach the class teacher directly. This gives both the teacher and parents/guardians a chance to chat informally and for children to see the continuing link between home and school. Your child will be issued with a homework book. Please feel free to make comments about any aspect of School life. Teachers will aim to address any concerns and we always welcome feedback.

Never be afraid to come and ask anything. That's what we're here for.

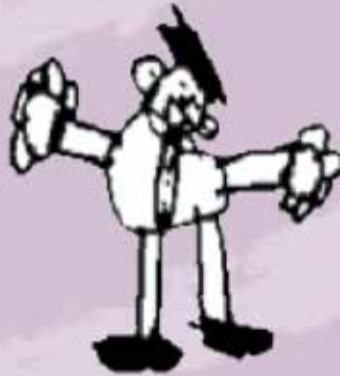

Mr Tabbett



Miss Hollis



Mrs Murray

What if they need to go to the toilet?

As part of the induction programme your child will have been shown where the toilets are. They will be encouraged to go to the toilet before playtime and lunch but if they need to go at any other time they just need to ask!

If your child should soil themselves at school, as far as possible, they will undertake their own care under the supervision of a known adult. If they are unable to do this then parent/guardian or emergency contact will be phoned. While waiting for an appropriate adult to arrive your child will remain in a suitable area e.g. toilets and be checked by a known adult.

What can I do to prepare my child for school?

Children enjoy being able to do things for themselves – they feel important and are less anxious. Here are some things you can do to help prepare your child for Primary 1:

- 🍏 Fasten zips and buttons
- 🍏 Change shoes (velcro fastenings will be much easier)
- 🍏 Dress and undress for P.E.
- 🍏 Use cutlery correctly
- 🍏 Use the toilet properly
- 🍏 Wash and dry hands
- 🍏 Use a hankie

What can I do to help my child learn?

- 🍏 Ask them to tell you about their day and what they have learned
- 🍏 Give praise and encouragement
- 🍏 Sing songs and say number rhymes
- 🍏 Look for numbers in the environment and count everyday objects
- 🍏 Play together
- 🍏 Cook together and enjoy the result!
- 🍏 Visit the local library and read them stories



Remember

Don't compare your child to others, they all learn at their own pace.

Finally

School should be a fun and positive experience. Your child is about to take the next step on their educational journey, please support them in all they do.

We hope that some of your questions have been answered and that you are somewhat reassured.

This is an exciting, new time for you and your child – share it with us and enjoy!



Newington Primary School



A group of Parents, Nursery Staff and P1 Teachers worked together a few years ago to produce this guide for parents. This partnership is key to ensuring the best possible transition for all our pupils.

This booklet will hopefully provide you with some of the key information needed for transition but remember there will be staff on hand to support you and your child through this key stage in their education.

Mr I. Torbett

Head Teacher



Where do you think the vehicles are going?

School Holidays

Term 1

Teacher training - Friday 17 and Monday 20 August 2018

First day - Tuesday 21 August 2018

Last day - Friday 12 October 2018

Autumn holiday - Monday 15 to Friday 26 October 2018

Term 2

First day - Monday 29 October 2018

Last day - Friday 21 December 2018

Christmas holiday - Monday 24 December 2018 to Friday 4 January 2019

Term 3

First day - Monday 7 January 2019

Teacher training - Thursday 21 and Friday 22 February 2019

Last day - Friday 5 April 2019

Spring holiday - Monday 8 to Monday 22 April 2019

Term 4

First day - Tuesday 23 April 2019

May Day holiday - Monday 6 May 2019

Last day - Friday 28 June 2019

Summer holiday - Monday 1 July 2019 to Friday 16 August 2019